

making work easy

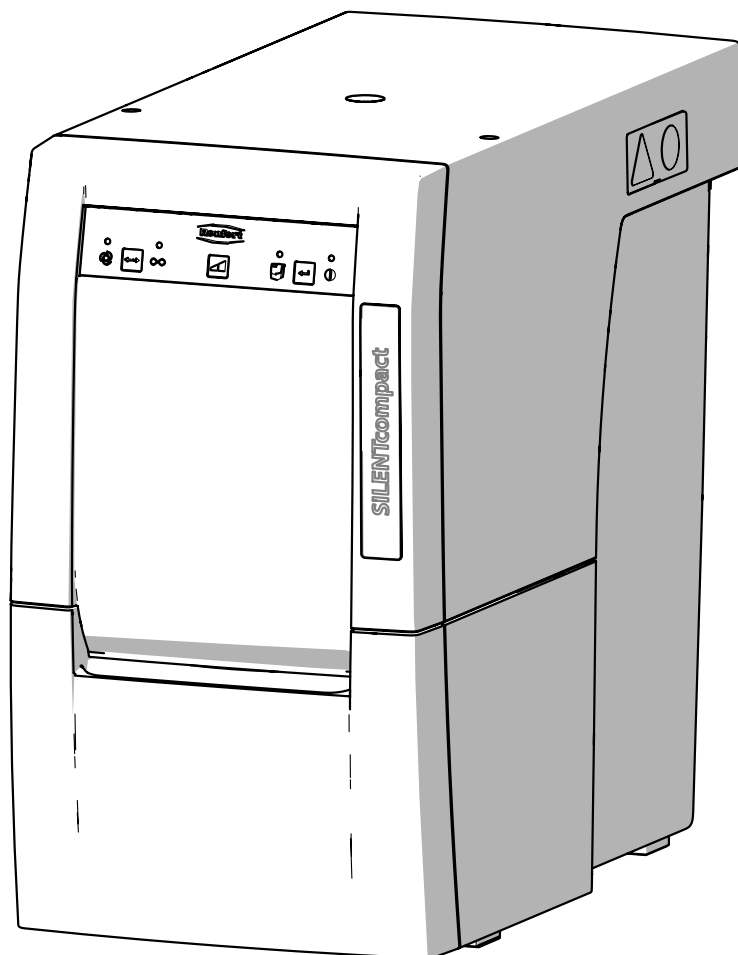

# SILENT compact

TRANSLATION OF THE ORIGINAL INSTRUCTIONS FOR USE

# Contents

EN

<b>1</b>	<b>Introduction</b>	<b>3</b>
1.1	Symbols	3
<b>2</b>	<b>Safety</b>	<b>3</b>
2.1	Intended Use	3
2.2	Improper Use	4
2.3	Ambient Conditions for Safe Operation	4
2.4	Ambient Conditions for Storage and Transport	4
2.5	Hazard and Warning Information	4
2.5.1	General Information	4
2.5.2	Specific Information	5
2.6	Authorized Persons	5
2.7	Disclaimer	5
<b>3</b>	<b>Product Description</b>	<b>6</b>
3.1	General Description	6
3.2	Components and Functional Elements	6
3.3	Scope of Delivery	7
3.4	Accessories	7
<b>4</b>	<b>Setting Up</b>	<b>8</b>
4.1	Unpacking	8
4.2	Setup	8
4.3	Electrical Connection	8
4.4	Connection to the Extraction Point	8
4.5	Electrical Connection	8
4.6	External Exhaust Air Route	9
<b>5</b>	<b>Operation</b>	<b>9</b>
5.1	Switching the Unit On	9
5.2	Select Mode: automatic / continuous operating	9
5.3	Suction Level	9
5.4	Filter Cleaning	9
5.5	Setting the switch-on threshold for the automatic operation mode	10
5.6	Deactivating the automatic start in the automatic operation mode	10
<b>6</b>	<b>Cleaning / Maintenance</b>	<b>10</b>
6.1	Cleaning	10
6.2	Empty Dust Drawer	11
6.2.1	Setting the time period "Empty Dust Drawer"	11
6.3	Change Fine Filter	12
6.4	Safety Mechanism	12
6.5	Spare Parts	12
6.6	Factory Settings	12
<b>7</b>	<b>Troubleshooting</b>	<b>12</b>
<b>8</b>	<b>Technical Data</b>	<b>14</b>
<b>9</b>	<b>Warranty</b>	<b>15</b>
<b>10</b>	<b>Disposal Information</b>	<b>15</b>
10.1	Disposing of Consumables	15
10.2	Disposing of the Unit	15
10.2.1	Disposal Instructions for countries in the EU	15

# 1 Introduction

## 1.1 Symbols

In the instructions for use and on the unit itself you will find these symbols with the following meanings:



### Danger

This indicates a direct risk of injury. Consult accompanying documents!



### Electrical current

This indicates a risk of hazard due to an electrical current.



### Attention

Disregarding this warning may result in damage to equipment.



### Note

This provides the operator with useful information to improve and ease use.



The device complies with the requirements of the applicable EU directives.



The device is subject to the EU directive 2002/96/EG (WEEE directive).



There is a FAQ video available on this topic in our video gallery under [www.renfert.com/p49](http://www.renfert.com/p49).



### ► List, particular attention should be paid

- List
- List

⇒ Instructions / appropriate action / input / operational sequence:

You will be asked to carry out the action in a specified order.

- ◆ Result of an action / reaction of the device / reaction of the program:

The unit or program reacts as a result of your actions or when a specific incident occurs.

Other symbols are explained as they occur.

## 2 Safety

### 2.1 Intended Use

This device is designed to extract dry, non-explosive dust.

The unit is intended solely for use in a commercial dental laboratory and dental practice.

The intended use also includes compliance with the instructions specified by the manufacturer concerning operation, servicing and maintenance.

## 2.2 Improper Use



**The equipment is not suitable for use with dental CAM units!**

**For information concerning SILENT extraction units for CAM machines, please refer to [www.renfert.com](http://www.renfert.com).**

Fire-promoting, easily flammable, red-hot, burning or explosive materials must not be suctioned into the device.

It is not permitted to suction liquids.

This device is not intended for private, household use.

Any use other than specified in these instructions is deemed improper and constitutes a misuse of the device.

The manufacturer shall not be liable for damages caused by improper use.

Only spare parts and accessories supplied or authorized by Renfert GmbH may be used with this product. If other spare parts or accessories are used, this could have a detrimental effect on the safety of the device, increase the risk of serious injury and lead to damage to the environment or the device itself.

## 2.3 Ambient Conditions for Safe Operation

The device may only be operated:

- Indoors
- Up to an altitude of 2,000 m above sea level,
- At an ambient temperature of between 5 - 40 °C [41 - 104 °F \*],
- At a maximum relative humidity of 80% at 31 °C [87.8 °F], dropping to a linear of up to 50% relative humidity at 40 °C [104 °F \*],
- With mains power where the voltage fluctuations do not exceed 10% of the nominal value,
- Under contamination level 2 conditions,
- Under over-voltage category II conditions,

\*) Between 5 - 30 °C [41 - 86 °F] the device can be operated at a relative humidity of up to 80 %. At temperatures between 31 - 40 °C [87.8 - 104 °F] the humidity must decrease proportionally in order to ensure operational readiness (e.g. at 35 °C [95 °F] = 65 % humidity, at 40 °C [104 °F] = 50 % humidity).

The device may not be operated at temperatures above 40 °C [104 °F].

## 2.4 Ambient Conditions for Storage and Transport

For storage and transport the following specifications to ambient conditions apply:

- Ambient temperature -20 – + 60 °C [- 4 – + 140 °F].
- Maximum relative humidity 80 %.

## 2.5 Hazard and Warning Information



### 2.5.1 General Information

- ▶ **If the device is not used in compliance with the supplied instructions, the safety of the device can no longer be guaranteed.**
- ▶ **The device may only be operated using a mains cable with the country-specific plug system. Any necessary alterations must be carried out by a qualified electrician.**
- ▶ **The device may only be operated if the information on the identification plate conforms to the specifications of your local mains power supply.**
- ▶ **The device may only be plugged into outlets which are connected to the protective conductor system.**
- ▶ **The mains plug must be easily accessible.**
- ▶ **Disconnect the device from the mains before carrying out work on the electrical parts.**
- ▶ **Check connection cables (such as power supply cords), tubes and housing (i.e. the key-pad) regularly for damage (i.e. kinks, cracks and porosity) or signs of ageing. Devices with damaged connection cables, tubes or housing parts or other defects must not be operated!**
- ▶ **Defective devices must be put out of service immediately. Remove the mains plug and ensure the device is not used. Send the device for repair!**
- ▶ **Only operate the device under supervision.**
- ▶ **Please observe the national accident prevention regulations!**
- ▶ **It is the responsibility of the operator that national regulations during operation and regarding a repeated safety inspection of electrical equipment are complied with. For Germany these are BGV A3 in relation with VDE 0701-0702.**

## 2.5.2 Specific Information

- ▶ The power socket on the device may only be used for the purpose specified in the instructions for use. The connection of other electronic devices could lead to material damage.
- ▶ Before connecting an electronic device to the power socket, ensure that the electronic device is first switched off.
- ▶ Read the operating instructions of the other appliance and comply with the safety instructions contained in the document.
- ▶ Please observe the national regulations and permitted exposure to dust in a working environment. Please ask the “National Institute for Occupational Safety and Health” or other responsible authority.
- ▶ Always refer to the relevant safety data sheets, when extracting hazardous materials.
- ▶ Always wear protective gear, when extracting hazardous materials.
- ▶ It is necessary to wear suitable personal protective equipment when emptying the dust drawer or cleaning, depending on the type of extracted material.
- ▶ When disposing of the extracted material or used filter, please observe the local specifications and accident prevention regulations!
- ▶ Make sure the dust drawer is fully closed during operation.
- ▶ Do not operate without a suction hose.
- ▶ Do not extract flammable or explosive gasses, fumes or dust.
- ▶ Do not extract hot materials.
- ▶ Do not extract liquids.
- ▶ If the dust extractor is employed to extract hazardous materials, appropriate personal protective gear must be worn and steps must be taken to ensure that the exhaust air is properly ventilated. Please refer to the associated safety data sheets for specific requirements.
- ▶ Dispose of extracted material according to local statutory regulations.

## 2.6 Authorized Persons

Operation and maintenance of the device may only be performed by qualified personnel.

Minors and pregnant women may only operate and service the device if they are wearing appropriate protective gear, in particular if the device is being used to extract hazardous materials.

Any repairs not specifically described in these operating instructions may only be carried out by a qualified electrician.

## 2.7 Disclaimer

Renfert GmbH shall be absolved from all claims for damages or warranty if:

- ▶ The product is employed for any purposes other than those specified in the operating instructions.
- ▶ The product is altered in any way other than those alterations described in the operating instructions.
- ▶ The product is not repaired by an authorized facility or if non-original Renfert parts are implemented.
- ▶ The product continues to be used despite obvious safety faults or damage.
- ▶ The product is subjected to mechanical impacts or is dropped.

# 3 Product Description

## 3.1 General Description

This is a workplace and appliance suction unit for extracting dust in dental laboratories. The extraction unit can be operated both manually and automatically, depending on the connected, electrical, dust-generating equipment.

## 3.2 Components and Functional Elements

- 1 Silent compact
- 2 Key-pad
- 3 Dust drawer
- 4 Fine filter
- 5 Mains cable
- 6 Suction hose
- 7 Exhaust air filter / Exhaust air outlet
- 8 Suction port
- 9 On / Off switch
- 10 Power supply
- 11 Device protection switch
- 12 Unit power socket
- 13 Service flap

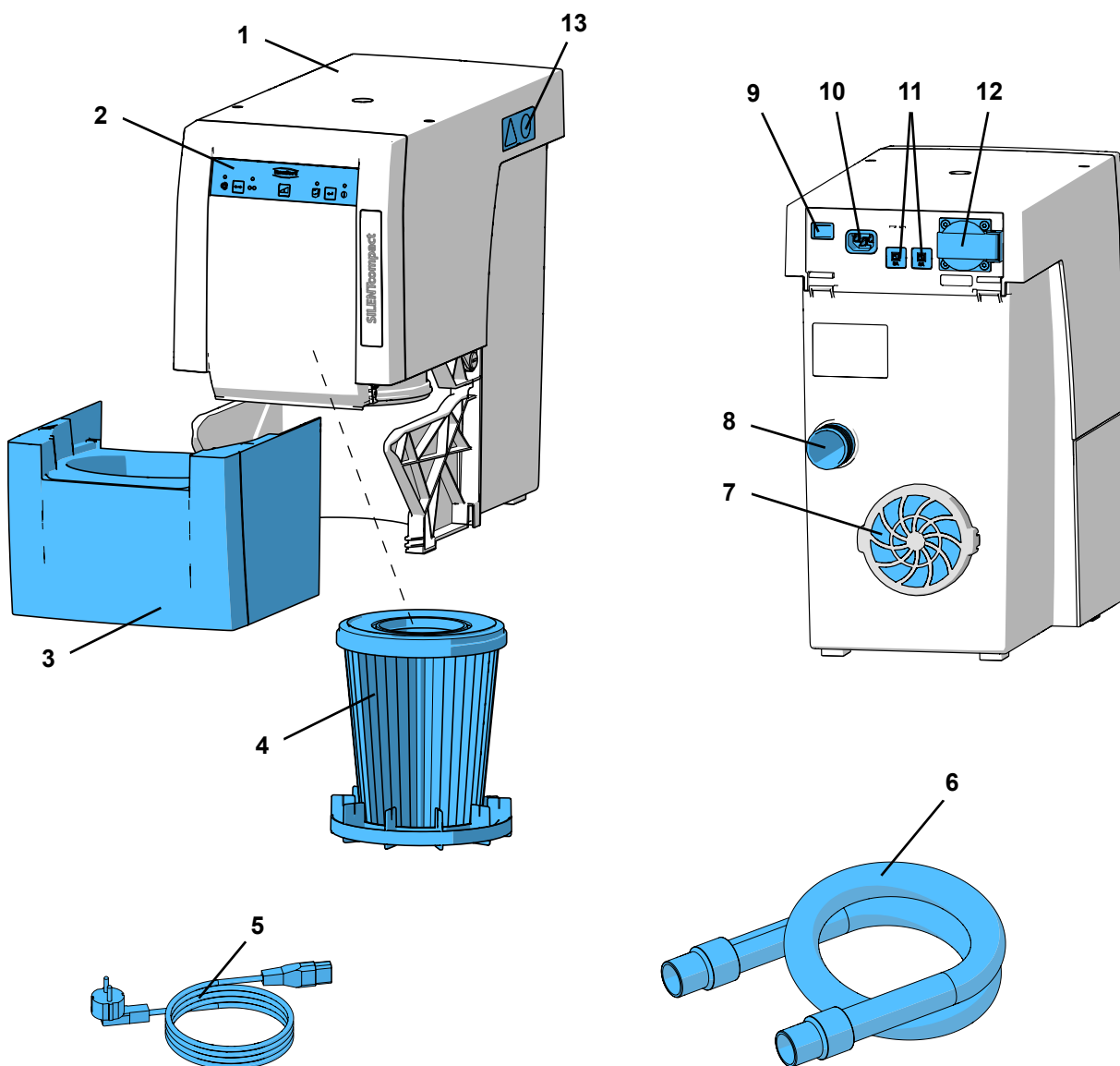

Fig. 1

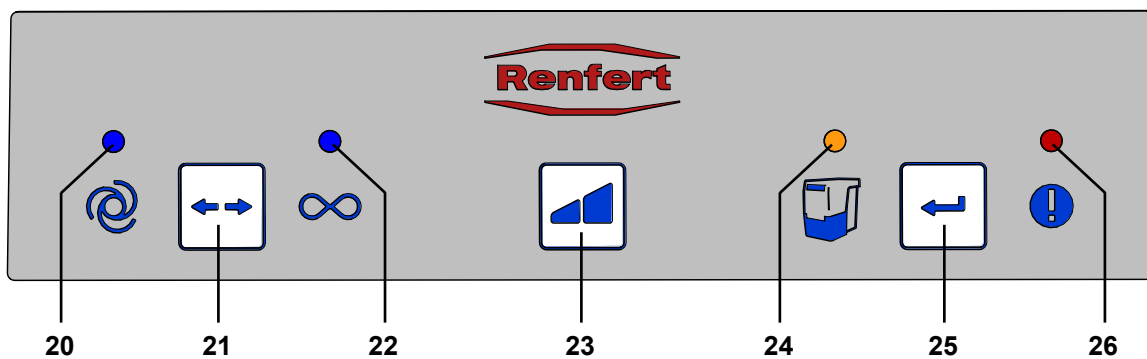

Fig. 2

- |  |  |
|--|--|
| <b>20</b> Display automatic operation                            | <b>23</b> Suction level key            |
| <b>21</b> Operating mode key,<br>automatic, continuous operation | <b>24</b> Display empty suction drawer |
| <b>22</b> Display continuous operation                           | <b>25</b> Enter key, save input        |
|  | <b>26</b> Display error message        |

### 3.3 Scope of Delivery

- 1 Silent compact
- 1 Quick Start Guide
- 1 Quick Reference Card
- 1 Power cable
- 1 Suction hose, 2 m, incl. 2 end mufflers

### 3.4 Accessories

- 2921 0003 End bushing set, 2 pieces
  - 90003 4240 Suction hose
  - 90003 4826 Suction hose, antistatic, 3 m, incl. 2 end mufflers
  - 90115 0823 Suction hose diameter 38 mm, 6 m
  - 90215 0823 Suction hose diameter 38 mm, 9 m
  - 90003 4305 Adapter for hose connection
  - 90003 4430 Universal suction hose adapter
  - 90003 4314 Y-junction
  - 2925 0000 Extractor clamp
  - 2925 1000 Glass screen with holder
  - 2926 0000 Y-Junction for dust extractor
  - 2934 0004 External exhaust air adapter SILENT compact
  - 2934 0007 90° angled connector Silent
- For further details or additional accessories, please see [www.renfert.com](http://www.renfert.com).

## 4 Setting Up

### 4.1 Unpacking

- ⇒ Remove the device and all the accessories from the delivery package.
- ⇒ Check the delivery for completeness (refer to the Scope of Delivery section).

### 4.2 Setup

The extraction unit is a free standing appliance which must not be operated in a lying position.

Position the extraction device so that:

- The exhaust vent (7, Fig. 1) is not blocked.
- The front of the device is easily accessible for removal of dust drawer.

If the device is to be installed in a cabinet, an opening for the exhaust air with the following dimensions must be provided, in addition to the openings for the suction hoses:

- Circular opening: Min. 120 mm diameters.
- Rectangular opening: Min. 170 x 65 mm.

It is advisable to use external ventilation (see accessories) (see chapter 4.6).

### 4.3 Electrical Connection



**Before connecting the device, ensure that the voltage information on the identification plate corresponds with your local power supply.**



**Arrange the conducting parts (plug sockets, plugs and couplings) and install the extension cord so that the protection class is retained.**

- ⇒ Switch the device OFF at the On / Off switch (9).
- ⇒ Connect the power cable (5, Fig. 1) to the power supply (10).
- ⇒ Insert the power plug into the building installed wall socket.

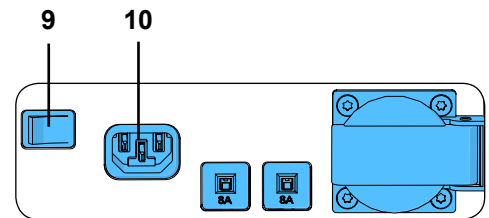

Fig. 3

### 4.4 Connection to the Extraction Point

- ⇒ Insert the suction tube (6, Fig. 1) into the suction port (8).
- ⇒ Connect the suction tube to the relevant suction point.
- ⇒ If necessary, shorten the suction tube.



**Caution, risk of injury!**

**When shortening the suction tube, please ensure that the integrated wire is cut as straight as possible.**



**If the diameter size does not correspond, please use an adapter (see accessories) to prevent a loss in suction performance.**



**Long suction hoses, tight bends and kinks will considerably reduce the extraction force at the extraction point.**



**Avoid steep pitches or hanging points along the hose path.**

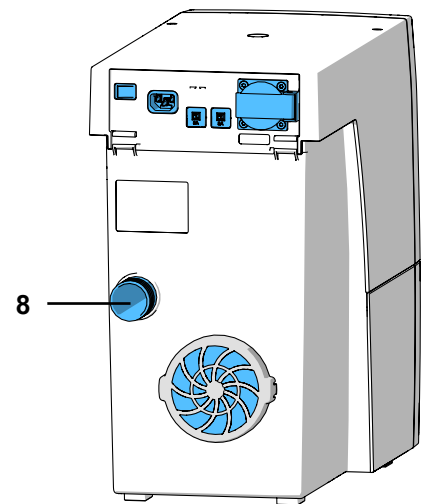

Fig. 4

### 4.5 Electrical Connection

- ⇒ Connect the electronic device to the power socket (12) at the back.



**When connecting an electronic device to the extraction unit, please ensure that the maximum permissible capacity for connected devices is not exceeded. (See chapter 8. Technical data).**

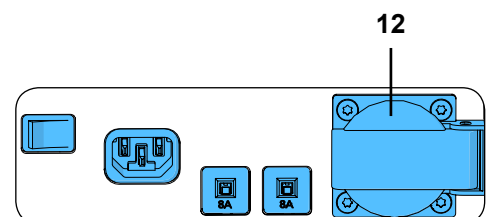

Fig. 5



## 4.6 External Exhaust Air Route

An external exhaust air route (see accessories) allows the extracted air to leave the laboratory.

The installation details are supplied with the external exhaust air route.



**When the extraction unit is used in conjunction with an external ventilation system, a significant quantity of air is extracted from the room per hour.**

**This can create negative pressure within the room which, when using an air dependent naked flame fed by gas, liquid or solid fuel, can cause poisonous gasses (e.g. carbon monoxide) to be drawn into the working area.**

**It is therefore essential to ensure that the fresh air supply is sufficient and that the environmental air pressure is maintained, this should then be monitored by an authorized specialist (e.g. a certified Gas Service Engineer).**

## 5 Operation

The extractor unit is operated via the buttons on the key-pad (Fig. 2).

### 5.1 Switching the Unit On

The extractor is switched ON and OFF at the On / Off switch (9).

When the unit is switched on:

- ◆ all 4 displays shortly light up (Display performance check),
- ◆ the extraction unit carries out an automatic filter cleaning.

Then the unit returns to the last set operating mode.

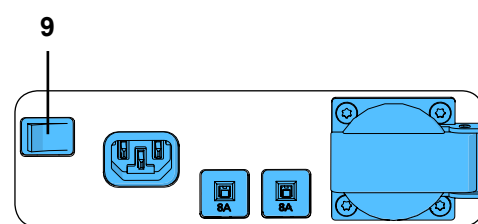

Fig. 6

### 5.2 Select Mode: automatic / continuous operating

The extraction unit has two operating modes.

The set operating mode is shown in the display (20) / (22).

- Automatic (20):  
In order to function, the extraction unit is dependent on an electronic device connected to the power socket (12).
- Continuous operating (22):  
The extraction unit runs continuously.

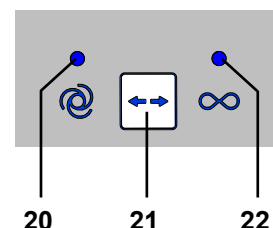

Fig. 7

⇒ Press the operating mode key (21).

- ◆ To change the operating mode.



**In order to start and stop the suction during continual operation, use the key operating mode (21). The on-off switch should not be used for this.**

### 5.3 Suction Level

The suction level key (23) allows selection between two suction levels.

The selected suction level is not shown.

The extraction unit always starts with the last set suction level.

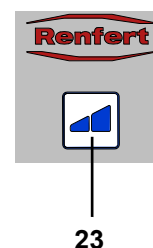

23

Fig. 8

### 5.4 Filter Cleaning

In order to guarantee maximum suction performance, the unit is equipped with an automatic cleaning function for the filter unit. The cleaning function takes approx. 8 sec.

The cleaning process is carried out:

- When the unit is switched on;
- Before the dust drawer is removed, when the cleaning function is activated (see chapter 6.2 Empty dust drawer);
- When the unit has been in operation (turbine running time) for more than 16 hrs without having been switched off in between.

## 5.5 Setting the switch-on threshold for the automatic operation mode



Set the switch-on threshold, the moment when a connected electronic device starts the extraction unit.

- ◆ Automatic mode is selected; the display (20) lights up (if the unit is not already in this mode, switch to automatic mode).
- ⇒ Press the operation mode key (21) for at least 3 seconds.
- ◆ The display for automatic operation (20) blinks.
  - ◆ The display for continuous operation (22) is off.
- ⇒ Switch the electronic device off or switch the device to stand-by mode (e.g. with a handpiece, only switch the control device on without activating the handpiece).
- ⇒ Press the enter key (25).
- ◆ The display automatic operation (20) lights up.
  - ◆ The display continuous operation (22) blinks.
  - ◆ An acoustic signal will confirm the setting.
- ⇒ Switch the electronic device on, e.g. activate the handpiece at the rpm at which the extraction unit should function and let it run for 3 - 5 seconds (to allow for over currents which occur when the device is initially switched on).
- ⇒ Press the enter key (25) (whilst the handpiece is still in use).
- ◆ The display for automatic operation (20) and continuous operation (22) light up at the same time for approx. 2 seconds.
  - ◆ An acoustic signal confirms the setting.

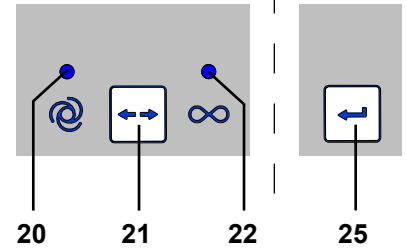

Fig. 9

The set switch-on threshold is saved.



**Devices with a stand-by mode should be switched on approx. 5 minutes before setting, in order to prevent measurement errors.**



**If there is a fault with the switch-on threshold, the error display (26, Fig. 2) will show and an acoustic signal will be emitted 3 times. Press the enter key (25) and repeat the programming.**

## 5.6 Deactivating the automatic start in the automatic operation mode

This special function allows the automatic extraction start in the automatic operation mode to be temporarily deactivated, e.g. when handpiece use is required without suction.

This special function is only available in the automatic operation mode.

- ◆ The automatic function is set (display (20) is alight).
- ⇒ Press the suction level key (23) for at least 3 seconds.
- ◆ An acoustic signal will confirm the deactivation.
  - ◆ The display automatic operation (20) blinks.
- In order to re-activate the automatic start:
- ⇒ Press keys (21, 23 or 25), or
- ⇒ switch the unit off at the on/off switch (9, Fig. 1).

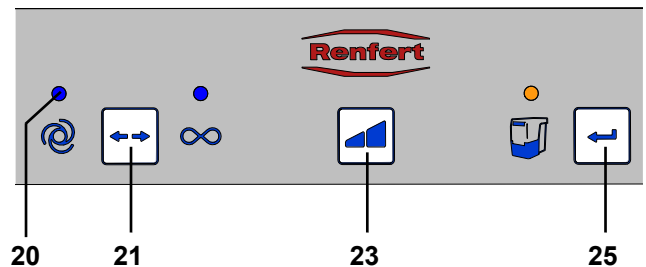

Fig. 10

# 6 Cleaning / Maintenance



**Opening the device, other than for the processes described below, is not permissible!**

## 6.1 Cleaning

Use a damp cloth to clean the outside of the unit.

Do not use abrasive or solvent-based cleaning agents.

## 6.2 Empty Dust Drawer



After the set time period has expired (see chapter 6.2.1), a signal to empty the dust drawer will occur. Before the dust drawer is emptied, a filter cleaning function is carried out so that loose dust particles fall into the dust drawer.

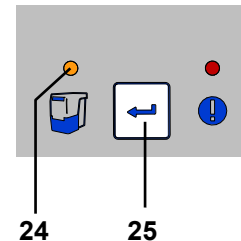

Fig. 11

The time period has expired:

- ◆ An acoustic signal will occur 3 times.
- ◆ The display dust drawer (24) lights up.

When the suction has stopped, an acoustic signal occurs 3 times and a filter cleaning function is carried out.

When the filter cleaning function has finished:

- ⇒ Pull the dust drawer (3, Fig. 1) out to the front and empty.
- ⇒ Replace the dust drawer until it clicks into place.
- ⇒ Press the enter key (25) (the counter which determines the time period is re-set).
  - ◆ An acoustic signal confirms the input.
  - ◆ The display dust drawer (24) light disappears.



***If the dust drawer is not emptied, the display for the dust drawer will remain alight (24, Fig. 11). When the unit is switched off/on an acoustic signal will occur to remind that the dust drawer needs emptying.***

### 6.2.1 Setting the time period “Empty Dust Drawer”



Five different time periods can be selected.

Time period / hrs.	Blink signal
2	1 x
5	2 x
10	3 x
50	4 x
100	5 x

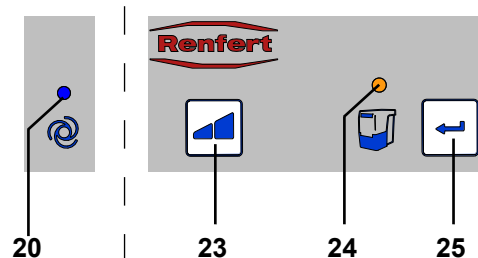

Fig. 12

To select time period:

- ⇒ Switch the unit off at the on/off switch (9, Fig. 1).
- ⇒ Switch the unit on at the on/off switch and keep the enter key (25) pressed until:
  - ◆ The display automatic mode (20) lights up.
  - ◆ The display dust drawer (24) signal blinks in correspondence to the set time period.



***When the unit is switched on all 4 displays shortly light up (Display performance check).***

- ⇒ Select the required time period by pressing the suction level key (23).  
By pressing this key it is possible to choose between 5 time periods. The selected time period is shown with the corresponding blink signal.

When the required time period has been selected:

- ⇒ Press the enter key (25).
  - ◆ The display dust drawer (24) lights up for 2 seconds.
  - ◆ An acoustic signal confirms the input.



***With strong dust-generating devices (e.g. sandblasting units) the time period for the “empty dust drawer” should be adjusted to 2 hrs. or 5 hrs.***

## 6.3 Change Fine Filter

As a fine filter, it contains a two-stage filter system category M. This ensures a high level of health protection and a long service life for the extraction system.

To ensure this function, please note the following:

- ▶ **If the suction power is no longer sufficient in spite of a filter cleaning, the fine filter must be changed.**
- ▶ **In general, the fine filter should be changed every 2 years.**



**Do not clean the fine filter manually (e.g. with compressed air, brush, water, etc.), as this leads to damage of the filter material!**



When installing the fine filter please ensure that it is positioned correctly, otherwise leakages may result. See the assembly instruction at the end of the instruction manual, which is also attached to the new fine filter.

## 6.4 Safety Mechanism

The extractor is safeguarded by two device overload switches (11, Fig. 1).

If an overload switch is released, it can be reset by pressing the button back in.



**If the protection switch is repeatedly released, this shows the device has a fault. Send the device to be repaired!**

## 6.5 Spare Parts

You can find components subject to wear and the spare parts on the spare part list in the internet at [www.renfert.com/p918](http://www.renfert.com/p918).

Enter the following item number: 29340000

The components excluded from the warranty (such as consumables or parts subject to wear and tear) are marked on the spare part list.

Serial number and date of manufacturing are shown on the type plate of the unit.



## 6.6 Factory Settings

⇒ Switch unit off (9, Fig.1).

⇒ Press the keys operating mode (21, Fig. 2) and suction level (23, Fig. 2) at the same time and switch the unit on (9, Fig. 1).

- ◆ All 4 displays blink thrice.
- ◆ All values are now re-set to the factory settings.

**Factory settings:**

Function / Feature	Setting range	Factory settings
Operating mode	Automatic mode / continuous mode	Automatic mode
Suction level	1 / 2	1
Time period	2 - 100 hrs.	50 hrs.
Switch-on threshold (automatic mode)		8 W

# 7 Troubleshooting

Trouble	Possible Cause	Corrective Action
During an interruption in operation, an acoustic signal occurs 3 times and then the filter cleaning function is carried out.	<ul style="list-style-type: none"> <li>After 16 hrs. constant operation (turbine running time) without having been switched off in between, the filter cleaning function is carried out.</li> </ul>	<ul style="list-style-type: none"> <li>Always switch appliances off at the on/off switch at the end of the working day (9, Fig. 1).</li> </ul>
When the unit is switched on, the display dust drawer (24, Fig. 12) lights up and an acoustic signal occurs 3 times.	<ul style="list-style-type: none"> <li>The time period for emptying the dust drawer has elapsed and the dust drawer has not yet been emptied.</li> <li>The emptying of the dust drawer has not been confirmed.</li> </ul>	<ul style="list-style-type: none"> <li>Empty the dust drawer and confirm by pressing the key (25, Fig. 12).</li> <li>Empty the dust drawer and confirm by pressing the key (25, Fig. 12).</li> </ul>
Display error (26, Fig. 2) lights up and an acoustic signal occurs 3 times.	<ul style="list-style-type: none"> <li>The difference between the chosen rpm at the handpiece and the stand-by current is too low; it is not possible to determine the switch-on threshold.</li> <li>It is not possible to determine the switch-on threshold.</li> </ul>	<ul style="list-style-type: none"> <li>Determine the switch-on threshold by increasing the rpm on the handpiece.</li> <li>Use the unit in continuous operating mode.</li> </ul>
The error message (26, Fig. 2) blinks.	<ul style="list-style-type: none"> <li>The electronic device has become too hot.</li> </ul>	<ul style="list-style-type: none"> <li>Switch the device off and allow it to cool down.</li> <li>Ensure sufficient cooling, e.g. with:               <ul style="list-style-type: none"> <li>- Chapter 4.2 installation instructions.</li> <li>- External ventilation (see chapter 4.6).</li> <li>- Change fine filter.</li> </ul> </li> </ul>
The suction performance is insufficient.	<ul style="list-style-type: none"> <li>The set suction performance is too low.</li> <li>There is a blockage or leak in the suction tube.</li> <li>Dust drawer is not airtight.</li> <li>The fine filter is full.</li> </ul>	<ul style="list-style-type: none"> <li>Select higher suction level.</li> <li>Check suction tube.</li> <li>Please observe the points in chapter 4.4</li> <li>Check the dust drawer is in the correct position (chapter 6.2).</li> <li>Switch the unit off and back on in order to initiate the filter cleaning function.</li> <li>Change the fine filter (see chapter 6.3) (if there is no improvement in suction performance after the filter cleaning process).</li> </ul>
Dust drawer is over full.	<ul style="list-style-type: none"> <li>The time period for "empty dust drawer" has been set too high.</li> </ul>	<ul style="list-style-type: none"> <li>Adjust to a lower time period (see chapter 6.2.1).</li> </ul>
The signal to empty the dust drawer shows even though the dust drawer is not yet full.	<ul style="list-style-type: none"> <li>The time period for "empty dust drawer" has been set too low.</li> </ul>	<ul style="list-style-type: none"> <li>Adjust to a higher time period (see chapter 6.2.1).</li> </ul>
The electronic device connected to the unit power socket cannot be operated.	<ul style="list-style-type: none"> <li>Suction is not switched on.</li> </ul>	<ul style="list-style-type: none"> <li>Switch the suction on.</li> </ul>
The suction starts even though the electronic device connected to the unit is not being used.	<ul style="list-style-type: none"> <li>The switch-on threshold for the automatic operation mode is set too low.</li> <li>Malfunction due to another device using the same power circuit.</li> </ul>	<ul style="list-style-type: none"> <li>Re-set the switch-on threshold for the automatic mode (see chapter 5.5).</li> <li>Connect the extraction unit and the device causing interference to different power circuits (phases).</li> </ul>
The suction does not stop when the electronic device is switched off.	<ul style="list-style-type: none"> <li>The switch-on threshold for the automatic operation mode is set too low.</li> <li>Malfunction due to another device using the same power circuit.</li> </ul>	<ul style="list-style-type: none"> <li>Re-set the switch-on threshold for the automatic mode (see chapter 5.5).</li> <li>Connect the extraction unit and the device causing interference to different power circuits (phases).</li> </ul>

Trouble	Possible Cause	Corrective Action
The suction does not start even though the electronic device is connected to the extraction unit.	<ul style="list-style-type: none"> <li>The switch-on threshold for the automatic operation mode is set too high.</li> <li>Malfunction due to another device using the same power circuit.</li> </ul>	<ul style="list-style-type: none"> <li>Re-set the switch-on threshold for the automatic mode (see chapter 5.5).</li> <li>Connect the extraction unit and the device causing interference to different power circuits (phases).</li> </ul>
The suction suddenly stops during automatic operation, even though the device connected at the appliance socket is still in use. The signal for automatic operation (20, Fig. 2) is still on.	<ul style="list-style-type: none"> <li>Malfunction due to another device using the same power circuit.</li> </ul>	<ul style="list-style-type: none"> <li>Connect the extraction unit and the device causing interference to different power circuits (phases).</li> </ul>
In the automatic operation mode, the suction starts after an unusually long delay time.	<ul style="list-style-type: none"> <li>Malfunction due to another device using the same power circuit.</li> </ul>	<ul style="list-style-type: none"> <li>Connect the extraction unit and the device causing interference to different power circuits (phases).</li> </ul>
The suction does not start after long transportation or after change of turbine.	<ul style="list-style-type: none"> <li>The connection plug behind the service flap (13, Fig. 1) is not completely inserted.</li> </ul>	<ul style="list-style-type: none"> <li>Open the service flap (13, Fig. 1) and push the connection plug fully up to the top.</li> </ul>
When the unit is switched on, not all of the displays light up.	<ul style="list-style-type: none"> <li>The display which does not light up is defect.</li> </ul>	<ul style="list-style-type: none"> <li>Contact Renfert / Service.</li> </ul>
The fuse is released when a connected electronic device is switched on.	<ul style="list-style-type: none"> <li>The total capacity for the connected devices is too high.</li> </ul>	<ul style="list-style-type: none"> <li>Observe the max. connected capacity (see chapter 8).</li> </ul>
The suction process in the continuous operation or automatic operation stops abruptly and the relevant displays are still on (20 / 22, Fig. 2).	<ul style="list-style-type: none"> <li>The suction turbine is overheated.</li> <li>The suction turbine is defect.</li> </ul>	<ul style="list-style-type: none"> <li>Switch the unit off and allow to cool down for at least 60 min.</li> <li>Check whether the suction tube is blocked. Eliminate blockage.</li> <li>Switch the unit off and then on again, so that the filter cleaning process can be carried out. Change the fine filter (see chapter 6.3) (if the filter cleaning function does not improve the suction performance).</li> <li>Change the suction turbine.</li> </ul>

## 8 Technical Data

	2934 0000	2934 1000	2934 1500
<b>Nominal voltage:</b>	<b>230 V</b>	<b>120 V</b>	<b>100 V</b>
Permissible mains voltage:	220 - 240 V	120 V	100 V
Mains frequency:	50 / 60 Hz	50 / 60 Hz	50 / 60 Hz
Suction turbine power *):	490 W	480 W	480 W
max. connecting power *):	1350 W	480 W	320 W
Total connected power *):	1840 W	960 W	800 W
LpA **) (at max. volume flow):	55 db(A)		
Filterquality:	Class M according to EN60335-2-69		
Weight (empty), approx.:	13,2 kg [29.1 lbs]		
Dimensions (width x height x depth):	245 x 440 x 500 mm [9.6 x 17.3 x 19.7 inch]		

\*) at nominal voltage

\*\*) Sound pressure levels according to EN ISO 11202

## 9 Warranty



*The suction motor has a guarantee of 3 years, with a maximum of duration of 1000 operating hours (motor running time).*

Provided the unit is properly used, **Renfert warrants all components for 3 years.**

Warranty claims may only be made upon presentation of the original sales receipt from the authorized dealer.

Parts which are subject to natural wear and tear (wear parts) and consumables are excluded from the guarantee. These parts are marked in the spare part list.

The warranty is voided in the case of improper use; failure to observe the operating, cleaning, maintenance and connection instructions; in case of independent repairs or repairs by unauthorized personnel; if spare parts from other manufacturers are employed, or in case of unusual influences or influences not in compliance with the utilization instructions.

Warranty service shall not extend the original warranty.

## 10 Disposal Information

### 10.1 Disposing of Consumables

Full dust bags and filters must be disposed of under compliance with locally applicable regulations. Depending on the material trapped by the filters, protective gear may need to be worn during disposal.

### 10.2 Disposing of the Unit

The unit must be disposed of by an authorized recycling operation. The selected firm must be informed of all possible health hazardous residues in the unit.

#### 10.2.1 Disposal Instructions for countries in the EU

To conserve and protect the environment, prevent environmental pollution and improve the recycling of raw materials, the European Commission adopted a directive that requires the manufacturer to accept the return of electrical and electronic units for proper disposal or recycling.



**Within the European Union, units with this symbol should not therefore be disposed of in unsorted domestic waste.**

Please contact your local authorities for more information on proper disposal.

**Hochaktuell und ausführlich auf ...  
Up to date and in detail at ...  
Actualisé et détaillé sous ...  
Aggiornato e dettagliato su ...  
La máxima actualidad y detalle en ...  
Актуально и подробно на ...**

**[www.renfert.com](http://www.renfert.com)**

Renfert GmbH • Industriegebiet • 78247 Hilzingen/Germany  
Tel.: +49 7731 82 08-0 • Fax: +49 7731 82 08-70  
[www.renfert.com](http://www.renfert.com) • [info@renfert.com](mailto:info@renfert.com)

Renfert USA • 3718 Illinois Avenue • St. Charles IL 60174/USA  
Tel.: +1 6307 62 18 03 • Fax: +1 6307 62 97 87  
[www.renfert.com](http://www.renfert.com) • [info@renfertusa.com](mailto:info@renfertusa.com)  
USA: Free call 800 336 7422



## 90002 1635

Feinfilterset • Fine filter set • Jeu filtre fin • Kit filtro fine  
Juego elemento filtrante fino • Комплект фильтров тонкой очистки

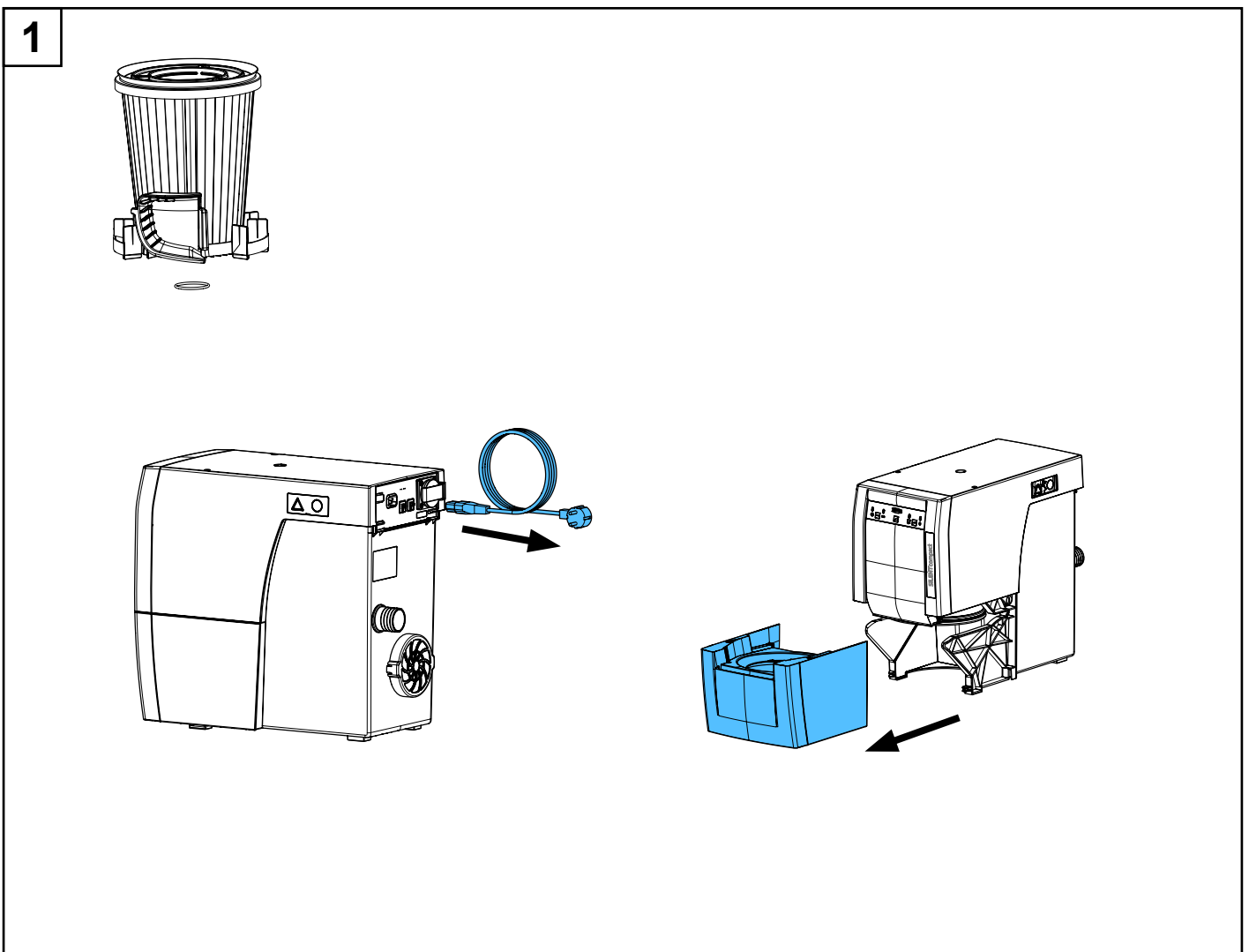
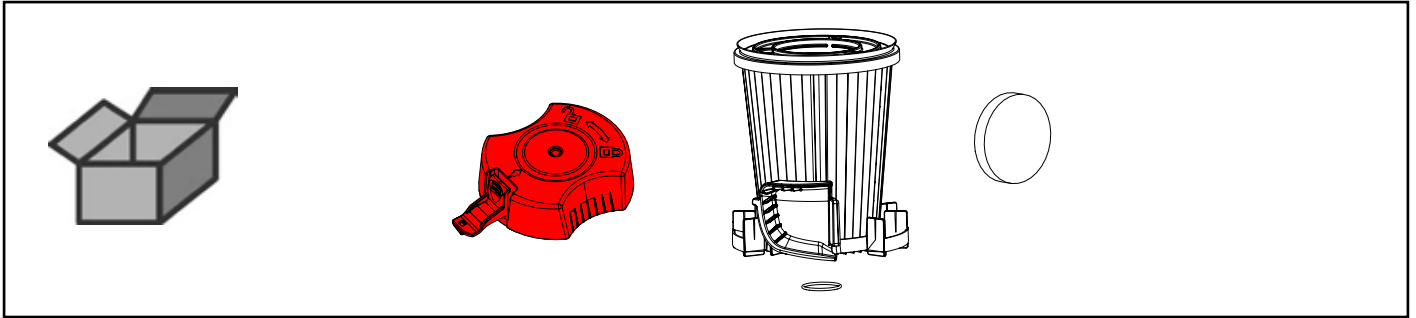

2

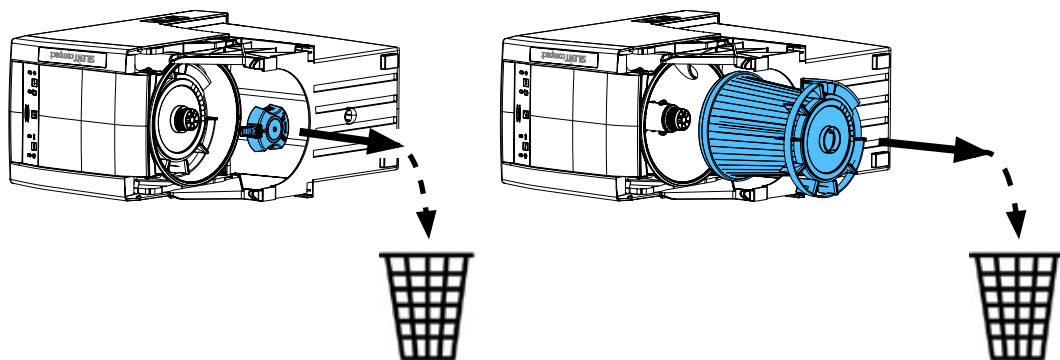
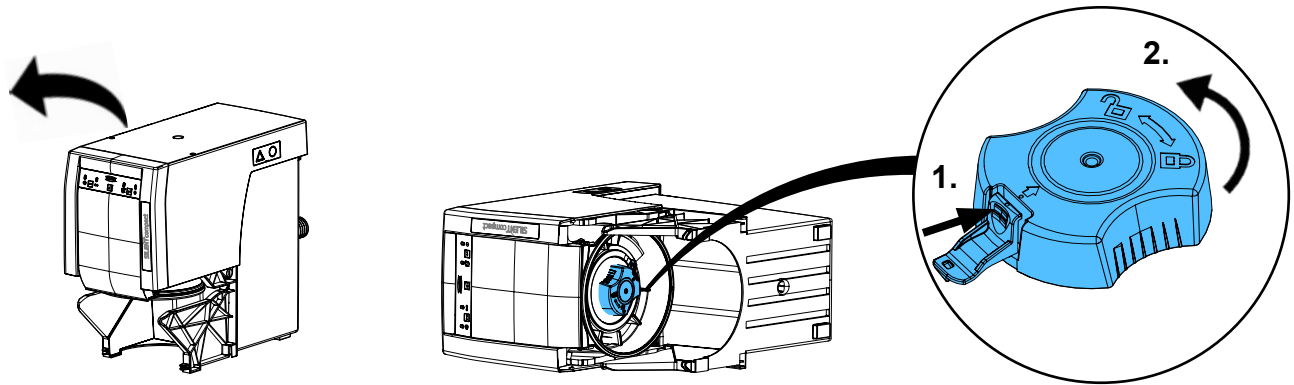

3

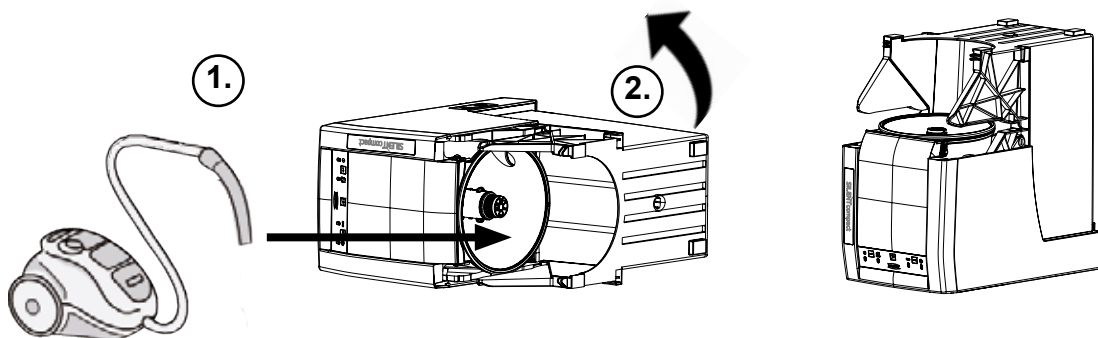

4

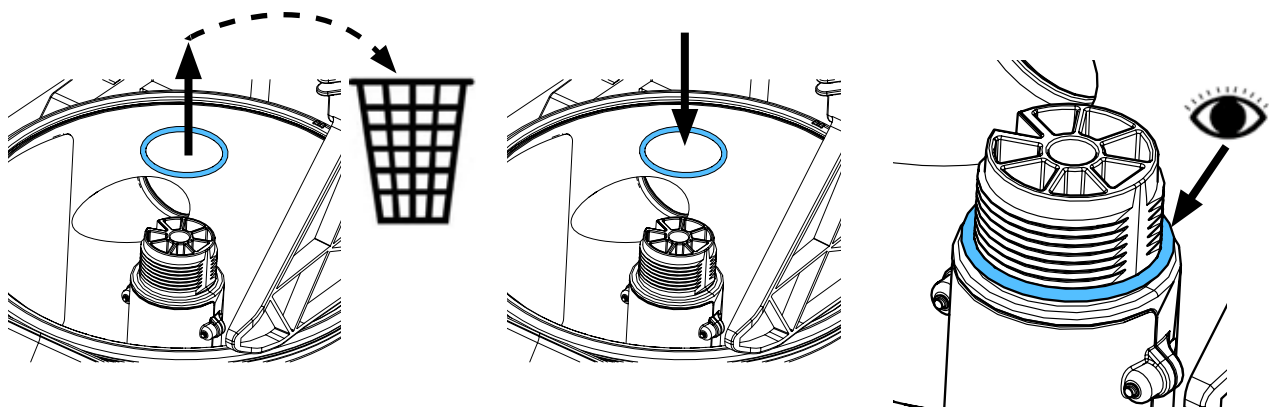

5

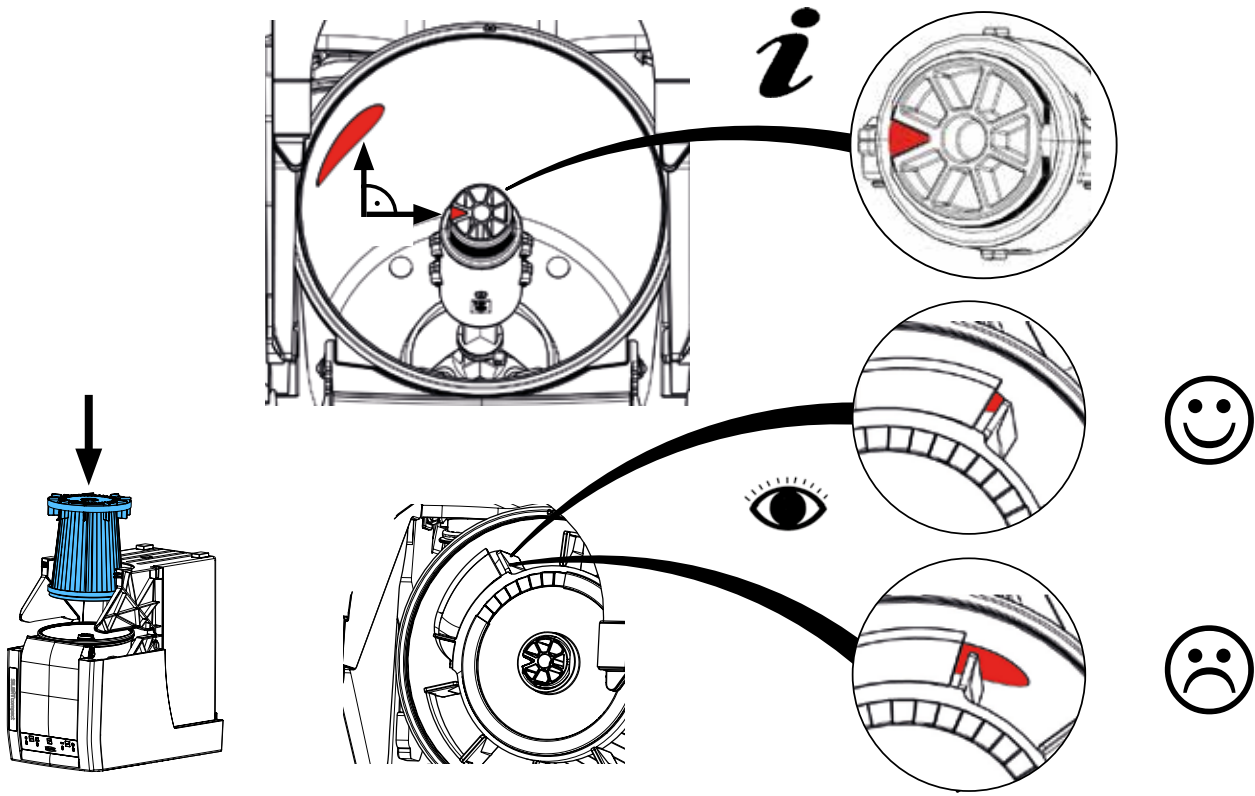

6

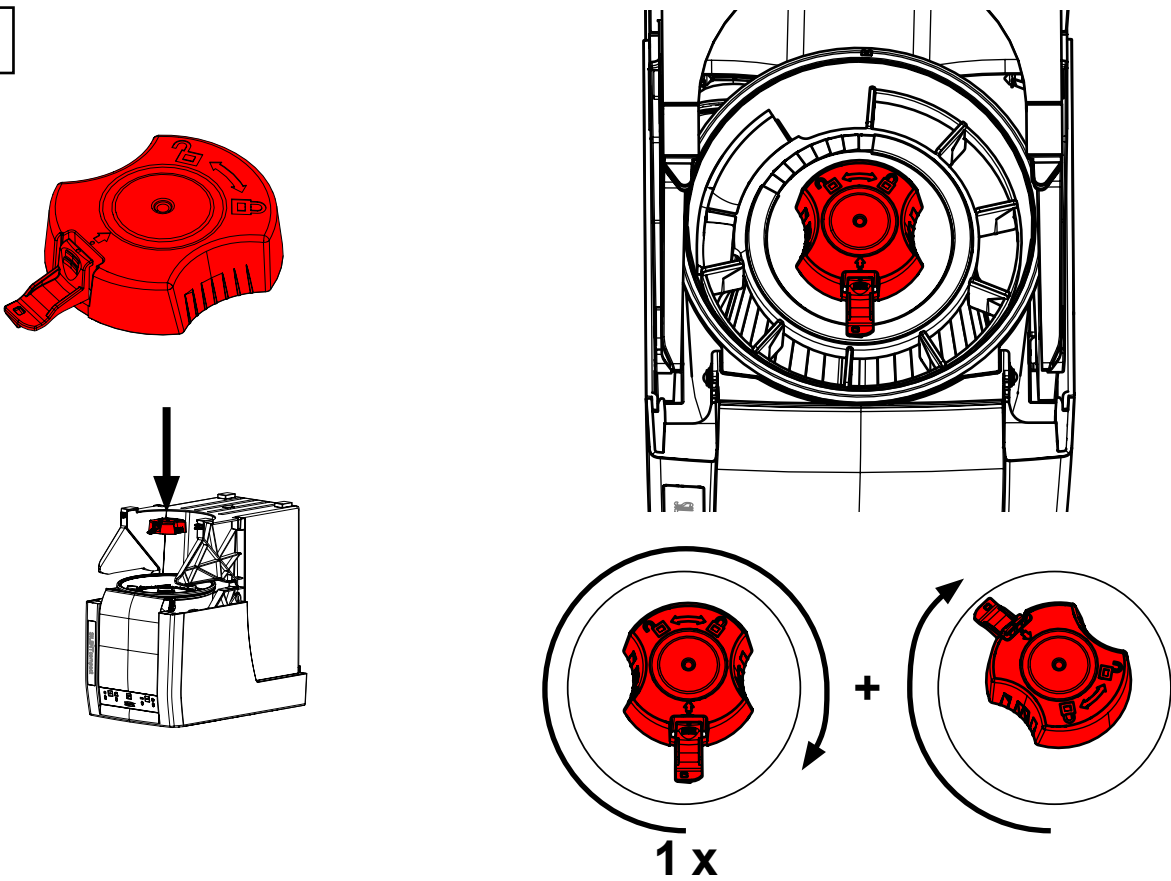

7

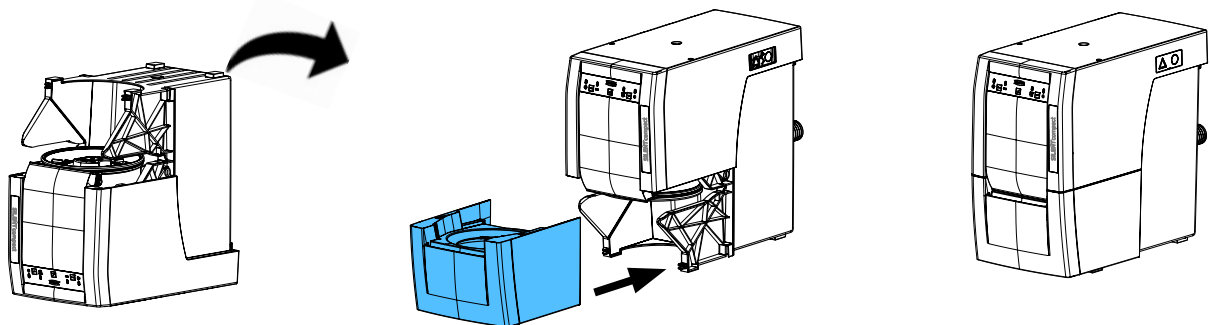

1

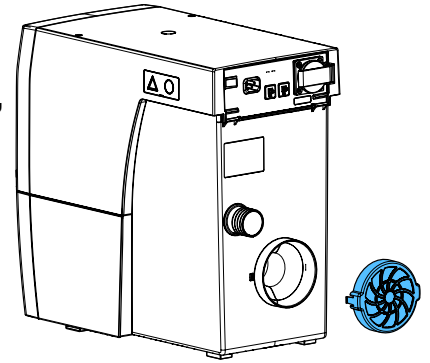
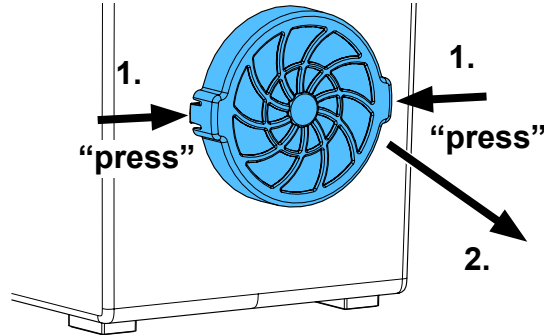
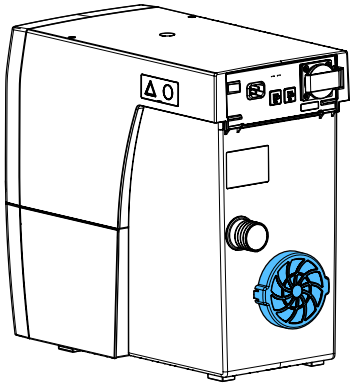
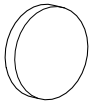

2

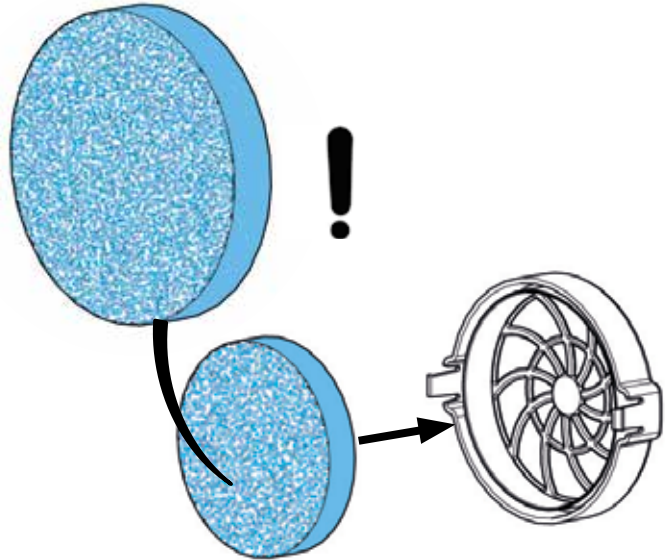
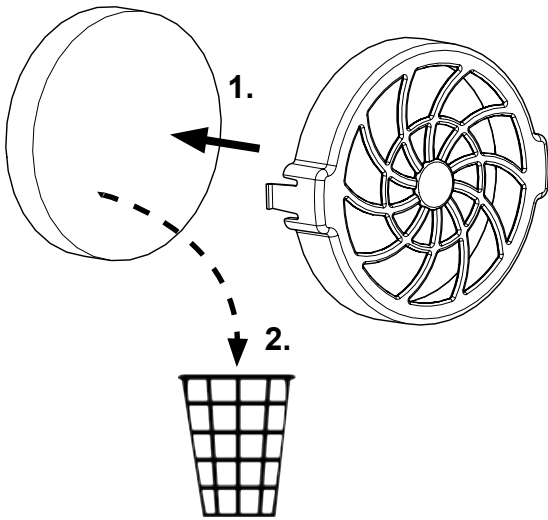

3

